

Matters of inquiry

Load inertia	(kgm ²) *Including all the components connected to the motor		
Load torque	Y	N	(N · m) *Including mechanical loss compensator
External force	Y	N	(N) Orientation
Moment load	Y	N	(N) Distance from the center (mm)
Radial load	Y	N	(N)
Axial load	Y	N	(N)
Motor mounting position			
Load-motor connection			Others
Environment	Operating environment		
	Operating temperature		
Load-mechanism schematic diagram (please fill out this field in detail, reporting information about position, dimensions, weight, material, etc.)			

Operating patterns

Velocity control	1cycle time (T)	[s]	Velocity control	Arresting time (t2)	[s]
	Transit time (t1)	[s]		Moving amount (angle)	[°]
	Acceleration time (t1a)	[s]		Rotation speed	[s-1]
	Feed time (t1c)	[s]		Operating time	(hr/day)
	Deceleration time (t1b)	[s]			

Accuracy conditions

Repeatability positioning precision ±	(°)
---------------------------------------	-----



For safe and reliable operation, it is essential to read the user's manual carefully before using this equipment.

SINFONIA TECHNOLOGY CO., LTD. continually upgrades and improves its products. Actual features and specifications may therefore differ slightly from those described in this catalog.

SINFONIA SINFONIA TECHNOLOGY CO., LTD.

Motion System Sales Dept.
Shiba NBF Tower, 1-30, Shibadaimon 1-chome, Minato-ku, Tokyo, 105-8564, Japan
TEL +81-3-5473-1826 FAX +81-3-5473-1845

SINFONIA TECHNOLOGY (SINGAPORE) PTE. LTD.
96 Robinson Road #13-02, SIF Building, Singapore 068899
TEL +65-6223-6122 FAX +65-6225-2729

PT. SINFONIA TECHNOLOGY INDONESIA
Graha Paramita 8th Floor Suite E Jl. Denpasar Raya Block D2 KAV. 8 Kuningan, Jakarta 12940, Indonesia
TEL: 021-252-3606 (hunting) FAX: 021-252-3608

SINFONIA TECHNOLOGY (THAILAND) CO., LTD.
Bangkok Sales Office
12th Floor Room 1205, 319 Chamchuri Square Building, Phayathai Road, Pathumwan Bangkok Bangkok 10330, Thailand
TEL +66-2160-5068 FAX +66-2160-5069

CODE
E76-515
Content of this catalogue may change due to product improvement without notice.
URL <http://www.sinfo-t.jp/eng>

1709B1S



ZMD/ZM series

High precision & improved reliability

SINFONIA

SINFONIA TECHNOLOGY CO., LTD.

Standard specifications

Model	ZMD-10026E-002	ZMD-10126E-002	ZMD-10033E-004	ZMD-10073E-002	ZMD-10103E-002	ZM-20A1-001	ZM-25A1-002		
Maximum torque	N·m	15	120	30	65	95	400	850	
Continuous torque	N·m	5	38	10	21 (15) ^{*3}	24 (17) ^{*3}	200	300	
Maximum current	A rms	3.4	13.5	3.6	7.1	10.0	22.0	42.0	
Rated current	A rms	1.4	4.2	1.2	2.2 (1.6)	2.4 (1.7)	11.0	15.0	
Maximum rotation	min ⁻¹	120	120	180	180	180	80	80	
Maximum output (capacity)	kW	0.16	1.44	0.51	1.13	1.51	1.67	5.86	
Repeat accuracy	arcsec							±2	
Winding resistance value (at line space of 20°C)	Ω	11.50	2.95	15.50	10.00	6.90	0.94	0.39	
Inductance (Average on 3 phase lines)	mH	50	15	40	25	15	20	10	
Axial run-out/Radial run-out accuracy	μm	70	70	70	70	70	70	70	
Allow axial load ^{*1}	N	800	3500	3500	3500	3500	18000	18000	
Allow moment load ^{*2}	N·m	40	150	150	150	150	700	700	
Protection structure (reference value)	-	(IP30)	(IP30)	(IP40)	(IP40)	(IP40)	(IP30)	(IP30)	
Rotor inertia (Calculated value)	kg·m ²	0.014	0.074	0.015	0.017	0.020	0.59	1.44	
Weight (Calculated value)	kg	5	20.9	8.3	11.2	13.7	113	154	
Total length	mm	45	105	113	143	173	120	155	
Outer dimensions (rotating part)	mm	φ225	φ225	φ150	φ150	φ150	585 (Rotor side φ400)	585 (Rotor side φ400)	
Hollow diameter	mm	φ80	φ50	φ50	φ50	φ50	φ78	φ78	
Number of pole pairs		20	20	20	20	20	24	24	
Resolution	ppr	2880000	2880000	1920000	1920000	1920000	2880000	2880000	
Axial run-out/Radial run-out Base level									

· If using radial load, axial load and moment load at the same time, please contact us.
 · This motor can be used with any type of servo driver. However, when using a servo-driver that differs from the one suggested, please be sure to use it below the rated current value.

^{*1} Use with horizontal installation / 0 radial load
^{*2} Use with horizontal installation
^{*3} Values without (): Ambient air temperature of 20°C
 Values with (): Ambient air temperature of 40°C

System configuration

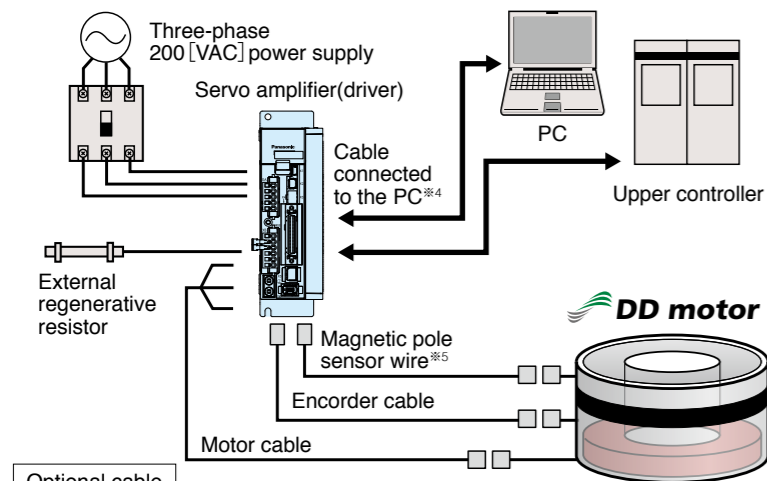

- Optional cable**
- Motor cable
 - Encoder cable
 - Magnetic pole sensor
 - External regenerative resistor
 - Interface connector-kit

※4. PC cable (USB mini-B cable) is not provided.
 ※5. Only required for DD motor with magnetic sensor

Operating environment

Ambient temperature	Operation : 0~40°C	Storage : -15~+70°C
Humidity	80% RH or less, no condensation	
Environment	Keep away from corrosive gas or dust (indoor use)	
Vibration/impact	9.8m/S ² or less	
Altitude	1,000m or less	

Dimensions

» ZMD-10026E-002

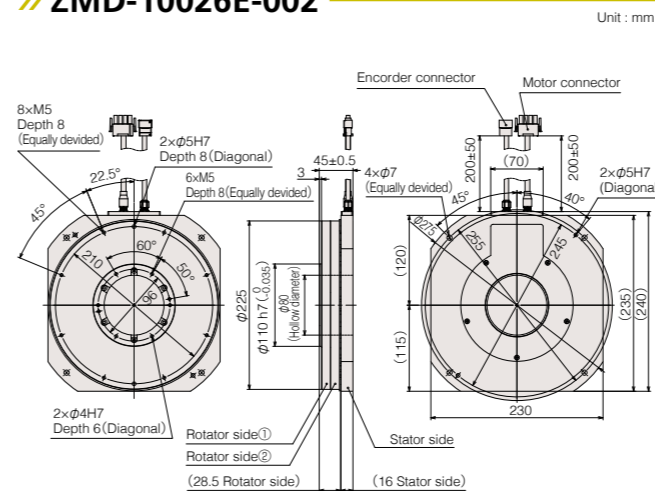

» ZMD-10126E-002

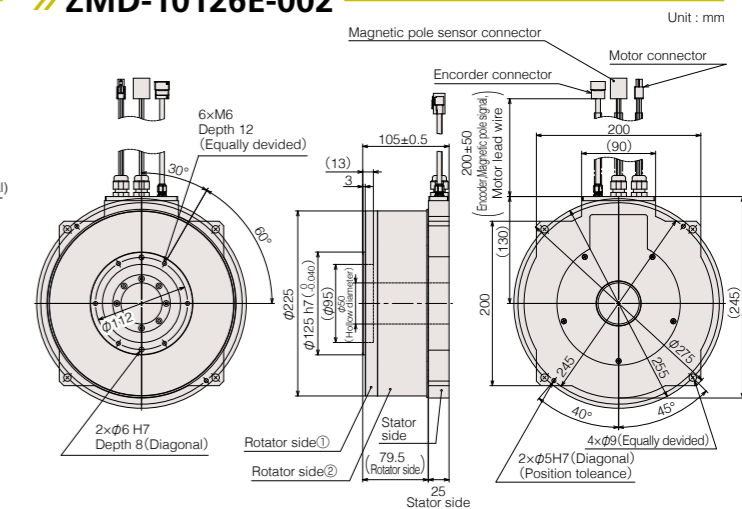

Model	ZMD-10026E-002	ZMD-10126E-002
Total length (L) mm	45	105

» ZMD-10033E-004/10073E-002/10103E-002

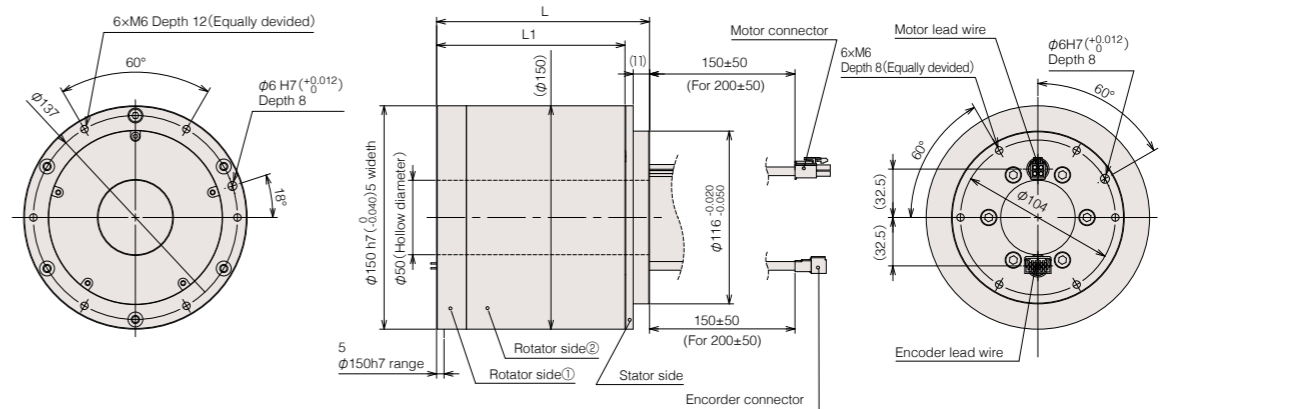

Model	ZMD-10033E-004	ZMD-10073E-002	ZMD-10103E-002
Diameter mm		φ150	
Total length (L) mm	113	143	173
Rotary side length (L1) mm	96.5	126.5	156.5

» ZM-20A1-001

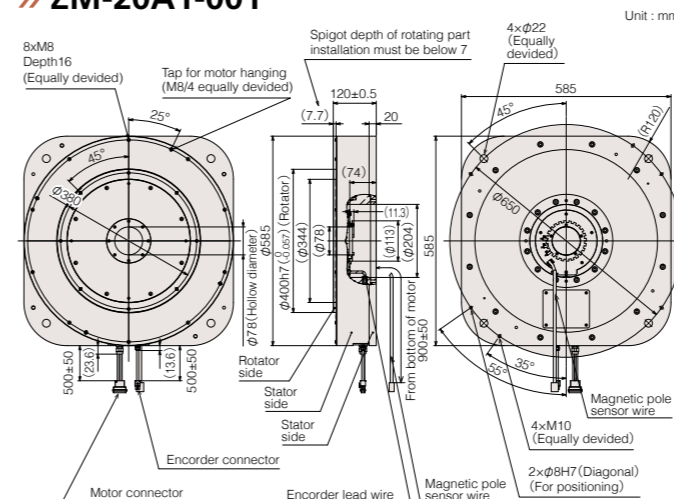

» ZM-25A1-002

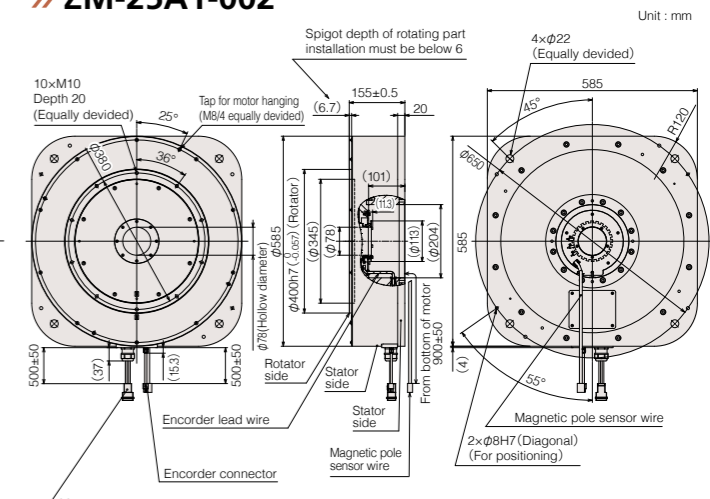

Model	ZM-20A1-001	ZM-25A1-002
Total length (L) mm	120	155

Torque performance

» ZMD-10026E-002

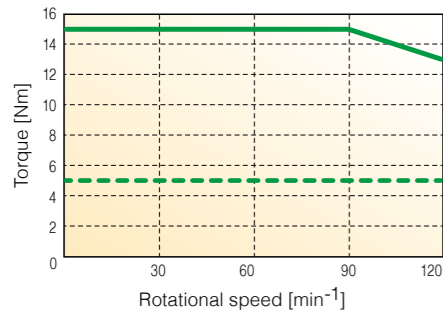

» ZMD-10126E-002

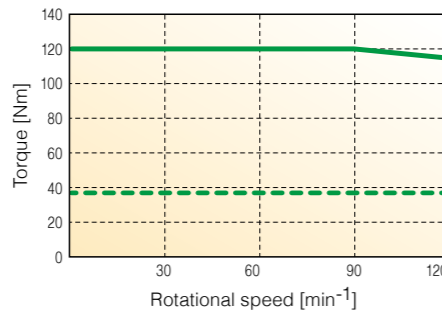

— Maximum Torque
- - - Continuous Torque

» ZMD-10033E-004

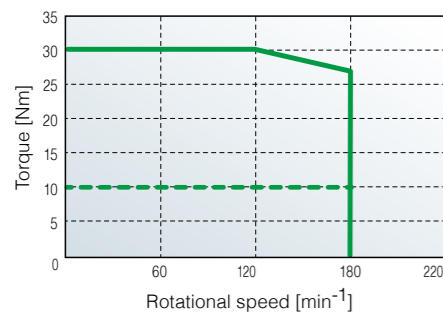

» ZMD-10073E-002

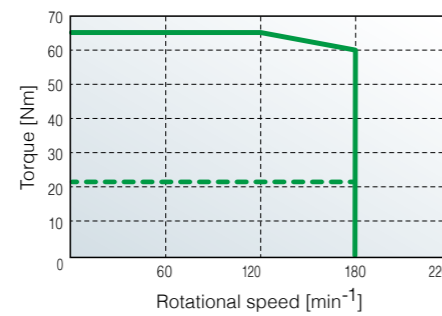

» ZMD-10103E-002

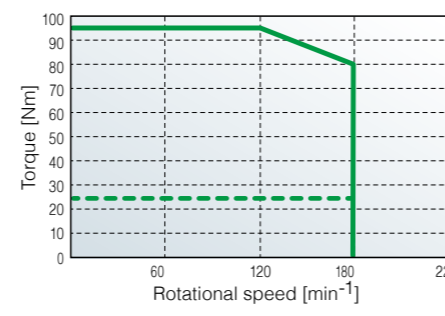

» ZM-20A1-001

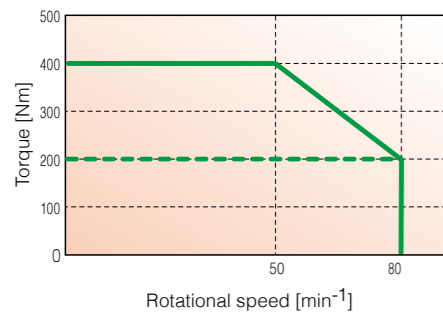

» ZM-25A1-002

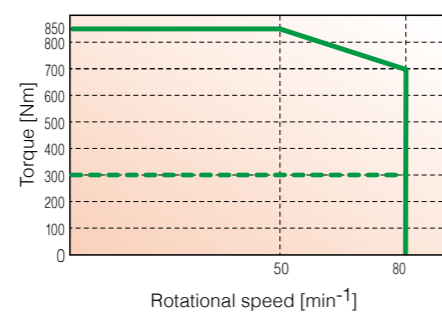

Pin map (Motor side)

Model	ZMD-10026E-002	ZMD-10126E-002	ZMD-10033E-004	ZMD-10073E-002	ZMD-10103E-002	ZM-20A1-001	ZM-25A1-002
Motor connector	350779-1	172167-1	172167-1	172167-1	172167-1	1-1747414-4	1-917808-2
Terminal for motor connector	350690-1	171638-1	171638-1	171638-1	171638-1	0-1747500-2	0-917805-2
Encoder connector	1-1903130-6	1-1903130-6	1-1903130-6	1-1903130-6	1-1903130-6	172169-1	172169-1
Terminal for encoder connector	1903115-2	1903115-2	1903115-2	1903115-2	1903115-2	170363-1	170363-1
Magnetic pole sensor connector	-	178964-3	-	-	-	178964-3	178964-3
Terminal for magnetic pole sensor connector	-	175287-2	-	-	-	175287-2	175287-2
Motor	Pin NO Line color Function 1 RD U 2 WT V 3 BK W 4 GN E	Pin NO Line color Function 1 RD U 2 WT V 3 BK W 4 GN E	Pin NO Line color Function 1 RD U 2 WT V 3 BK W 4 GN E	Pin NO Line color Function 1 RD U 2 WT V 3 BK W 4 GN E	Pin NO Line color Function 1 RD U 2 WT V 3 BK W 4 GN E	Pin NO Line color Function 1 BK U 2 RD B+ 3 YE Z+ 4 BK E	Pin NO Line color Function A1 BK U A2 BK V B1 BK W B2 BK E
Encoder	B1 BK OV B2 BK/WT 5V B3 GN A+ B4 GN/WT A- B5 RD B+ B6 RD/WT B-	B1 BK OV B2 BK/WT 5V B3 GN A+ B4 GN/WT A- B5 RD B+ B6 RD/WT B-	B1 BK OV B2 BK/WT 5V B3 GN A+ B4 GN/WT A- B5 RD B+ B6 RD/WT B-	B1 BK OV B2 BK/WT 5V B3 GN A+ B4 GN/WT A- B5 RD B+ B6 RD/WT B-	B1 BK OV B2 BK/WT 5V B3 GN A+ B4 GN/WT A- B5 RD B+ B6 RD/WT B-	1 GN A+ 2 RD B+ 3 YE Z+ 4 GN/WT A- 5 RD/WT B- 6 YE/WT Z-	1 GN A+ 2 RD B+ 3 YE Z+ 4 GN/WT A- 5 RD/WT B- 6 YE/WT Z-
Magnetic pole sensor	-	B1 BK 5V B2 BK/WT OV B3 - -	-	-	-	B1 BK 5V B2 BK/WT OV B3 - -	A1 GN CS3 A2 GN/WT CS2 A3 RD CS1

※Cable is optional

Optional accessories

Servo driver We recommend to use Panasonic A5L, A6L driver in a combination with our motors

By combining reliable servo driver with accumulated technology, DD motor could be used more easily and precisely.



Specifications (A5L)

Model	MBDHT2510L01/L04	MCDHT3520L01/L04	MDDHT3530L01/L04	MEDHT7364L01/L04	MFDHT390L01/L04
Power	Main circuit power supply	3-phase / Single phase 200~240V			3phase 200V
	Control circuit power supply	Single phase 200~240V			Single phase 200~230V
Rated current A	2.6	4.1	5.9	13.4	18.7
Maximum current A	7.8	12.3	16.9	40.2	56.1
Control system	IGBT PWM sinewave control drive				
Encoder feedback	A/B phase, initialization signal differential input				
Communication function	USB	Setting of parameter and state monitoring are possible by connecting to PC			
	RS232	1 : 1 communication to a host			
	RS485	1 : N communication to a host			
Control mode	①Position control ②Velocity control ③Torque control ④Position/Velocity control ⑤Position/Torque control ⑥Switching from parameter by modes of velocity/ torque control				
Applicable motor	ZMD-10026E ZMD-10033E ZMD-100073E	ZMD-10103E	ZMD-10126E	ZM-20A1	ZM-25A1

Specifications (A6L)

□ : Safety function N : No safety function T : safe torque off (STO)

Model	MBDL□25SM/SL	MCDL□35SM/SL	MDDL□45SM/SL	MEDL□83SM/SL	MFDL□A3SM/SL
Power	Main circuit power supply	3-phase / Single phase 200~240V			3-phase 200V
	Control circuit power supply	Single phase 200~240V			Single phase 200~230V
Rated current A	2.4	4.1	5.9	12.5	27.1
Maximum current A	7.4	13.3	17.1	37.5	72.1
Control system	IGBT PWM sinewave control drive				
Encoder feedback	A/B phase, initialization signal differential input				
Communication function	USB	Setting of parameter and state monitoring are possible by connecting to PC			
	RS232	1 : 1 communication to a host			
	RS485	1 : N communication to a host			
Control mode	①Position control ②Speed control ③Torque control ④position/Speed control ⑤Position/Torque control ⑥Switching from parameter by modes of velocity/ torque control				
Applicable motor	ZMD-10026E ZMD-10033E ZMD-100073E	ZMD-10103E	ZMD-10126E	ZM-20A1	ZM-25A1

Cable

	ZMD-10026E-002	ZMD-10126E-002	ZMD-10033E-004	ZMD-10073E-002	ZMD-10103E-002	ZM-20A1-001	ZM-25A1-002
Motor cable	LED-AD0-005-03(3m) LED-AD0-005-05(5m)	LED-AD0-004-03(3m) LED-AD0-004-05(5m)			LED-AD0-006-03(3m) LED-AD0-006-05(5m)		LED-AD0-007-03(3m) LED-AD0-007-05(5m)
Encoder cable	LED-AD3-005-03(3m) LED-AD3-005-05(5m)				LED-AD3-006-03(3m) LED-AD3-006-05(5m)		
Magnetic pole sensor cable	LED-AD0-008-03(3m) LED-AD0-008-05(5m)					LED-AD0-008-03(3m) LED-AD0-008-05(5m)	